



GALAXY PRO

V2/V2C/V4/V4C/V6/V8

OPERATION MANUAL

Please read this manual carefully before using the product!

Hangzhou Gelato Tech Co., Ltd.

No. 585 Shushangwang, Jinhua Town, Xiaoshan District,
Hangzhou, China
Post code: 311253

BEFORE STARTUP

- 1.1** Transportation and unboxing
- 1.2** Verify nameplate information and ensure correct power supply
- 1.3** Get to know your equipment
- 1.4** Detachable parts and operating guidelines
- 1.5** Accessories
- 1.6** Operating environment and precautions
- 1.7** The difference between glass and ventilation panels
- 1.8** How to replace the glass
- 1.9** Warnings and residual risks
- 1.10** Waste electrical and electronic equipment (WEEE)

STARTUP AND OPERATION

- 2.1** Understanding the control interface
- 2.2** Cylinder cleaning (without ice cream)
- 2.3** Led spot light
- 2.4** Anti-fog & condensation system
- 2.5** Production capacity guidelines
- 2.6** Production modes and parameter adjustments
- 2.7** Continuous production
- 2.8** Storage mode and parameter adjustments
- 2.9** Night storage mode and parameter adjustments
- 2.10** Standard cleaning procedures

EQUIPMENT MAINTENANCE

- 3.1** Daily maintenance
- 3.2** Periodic maintenance
- 3.3** Emergency and malfunctions
- 3.4** Warranty information

1.1 Transportation and unboxing

RECEIVING

The machine has carefully packaged externally to ensure that it is not damaged during transportation and storage.

External packing include:

- A wooden bracket
- A cardboard box

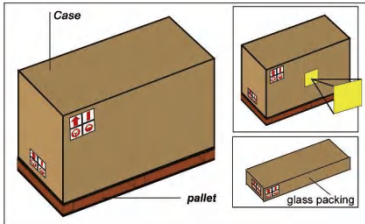

There are labels on the packages that give details of the equipment.

- Dimensions: length * width * height
- Lifting connection point

⚠ Note: after packing, please keep it in a dry indoor environment to avoid rain or snow.

Forklift rising

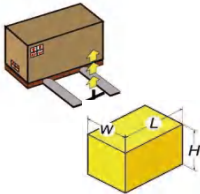

Storage

Whether short-term or long-term storage it must be kept indoors to avoid the impact of weather factors.

Handle with care.



External dimension

MODEL	L	W	H
GALAXY PRO V2	950mm	840mm	1000mm
GALAXY PRO V2C	1050mm	820mm	1000mm
GALAXY PRO V4	1050mm	1120mm	1150mm
GALAXY PRO V4C	1900mm	1100mm	1150mm
GALAXY PRO V6	1800mm	1100mm	1150mm
GALAXY PRO V8	2140mm	1100mm	1150mm

⚠ Any damage caused by operational errors is not covered by the warranty.

1.1

Transportation and unboxing

UNLOADING

The placement of the packaged machine must follow the instructions in the notes or on the packaging.

 Please use the appropriate forklift to unload (its load must match that of the packaged machine)

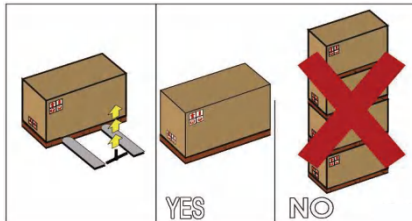

PACKAGING INSPECTION

Please check whether the outer packing is in good condition when you receive the goods. If the outer packing has obvious damage, then the product may have been damaged, customer must unpack and inspect the goods with the shipper on site. All damage caused by improper handling and storage irrelevant to the manufacturer.

In case of the above situation, Please:

- A) Contact your regional agent or manufacturer
- B) Present the relevant written report
- C) Send a copy of the relevant report to the manufacturer or regional agent

UNPACKING

 All packaging materials are recyclable and can be treated in accordance with local laws. Please ensure that the plastic materials of the equipment are properly disposed to prevent harm to children.

PORTER REQUIREMENTS

We recommend that the gelato (ice cream) machine should be handled by someone skilled in the use of a forklift and operated in strict accordance with safety standards.

HANDLING

The machine needs to be lifted by a forklift truck or other tool that capable of carrying twice the weight of the cargo (see nameplate for weight). Operators must maintain a certain distance from the cargo area to ensure that personnel and other property will not be damaged if the cargo falls due to improper handling. Please move the cargo slowly to prevent tipping over.

1.1

Proper unboxing and preparation for use

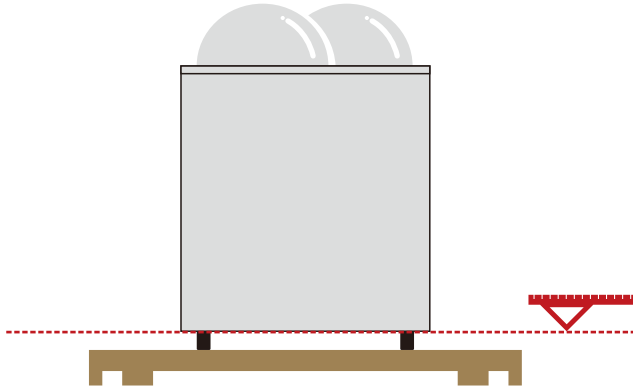

Before use, please let the machine stand horizontally for 6 hours.

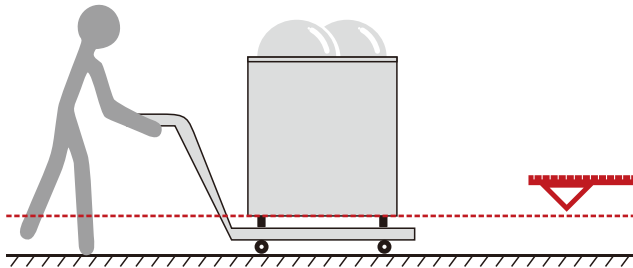

Please keep it level when moving the equipment.

1.2

Verify nameplate information and ensure correct power supply



PRO V2

Dimensions	720mm*600mm*885mm
Weight	150 KG

Power supply	16A Single phase 220V 50/60HZ
Peak power	1900W

PRO V2C

Dimensions	720mm*600mm*2400mm
Weight	195 KG

Power supply	16A Single phase 220V 50/60HZ
Peak power	1900W

PRO V4

Dimensions	1000mm*800mm*910mm
Weight	240 KG

Power supply	16A Single phase 220V 50/60HZ
Peak power	3800W

PRO V4C

Dimensions	1600mm*800mm*2400mm
Weight	360 KG

Power supply	16A Single phase 220V 50/60HZ
Peak power	3800W

PRO V6

Dimensions	1500mm*800mm*910mm
Weight	360 KG

Power supply	32A Three phase 380V 50/60HZ
Peak power	5700W

PRO V8

Dimensions	2000mm*800mm*910mm
Weight	460 KG

Power supply	32A Three phase 380V 50/60HZ
Peak power	7600W

Cooling type	Air cooling
Refrigerant	R290

Capacity per batch	Maximum 3.0L / Minimum 1.5L
Initial batching time	12 - 18 Minutes

1.3

Get to know your equipment



PRO V2



PRO V4



PRO V6



PRO V8



PRO V2C

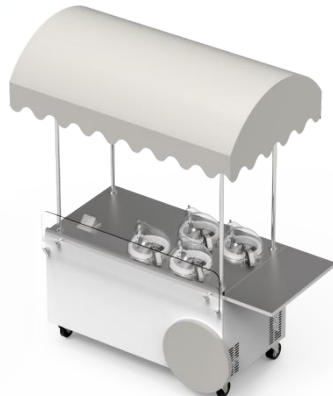

PRO V4C

1.4

Detachable parts and operating guidelines



Cylinder lid



Lid Hinge

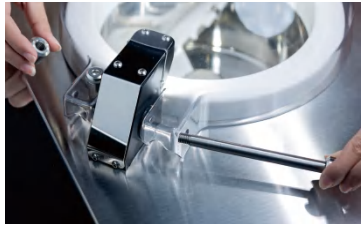

Remove the hinge nut and pull out the hinge to take out the cover.



Drainage block



When draining after cleaning, pull the drainage block outward in a clockwise direction.

1.4

Detachable parts and operating guidelines



**Self-adaptive
anti-frozen scraper**

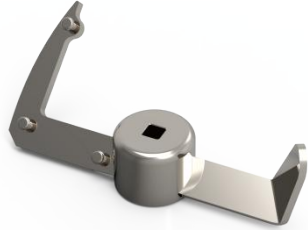

Steel agitator



Align the slot points of the scraper with the screws of the mixing blades.



Use both hands to hold both arms of the blade and slide it down steadily along the central shaft until it reaches the bottom of the cylinder



After installation, ensure that the edge of the scraper is tightly attached to the cylinder wall and bottom.

1.5

Accessories



Anti-bacterial spatular & scoop holder



Place the silicone ring onto the edge of the cylinder.



Rotate it to align with the screw locking point.



Spatular



Insert the spatulas into the holder as shown in the picture.

1.6

Operating environment and precautions

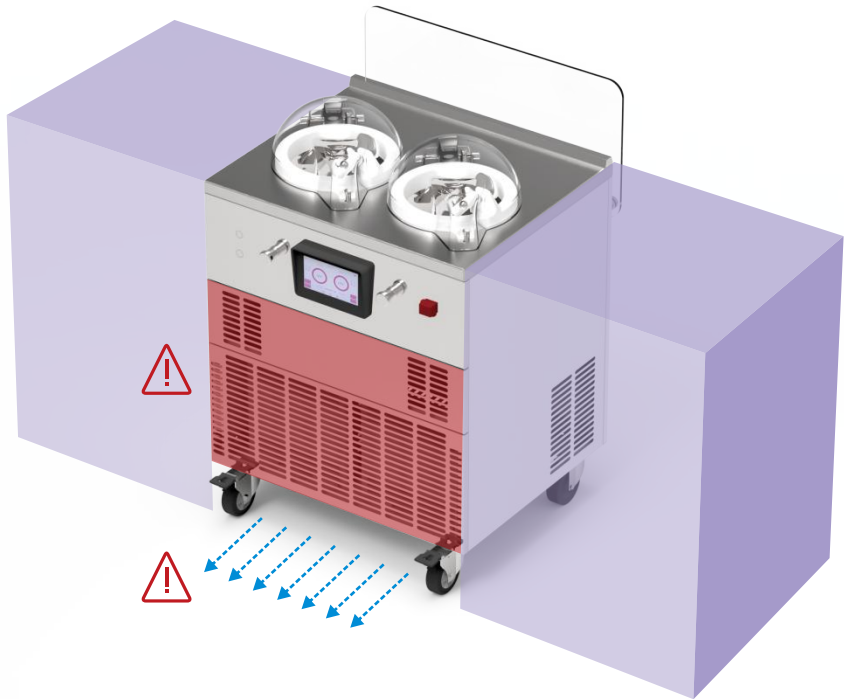

Do not block the heat dissipation space underneath the bottom of the device.



Do not block the air intake vent.

1.7 The difference between glass and ventilation panels



If not embedded in the bar, the ventilation panel needs to be replaced with glass.

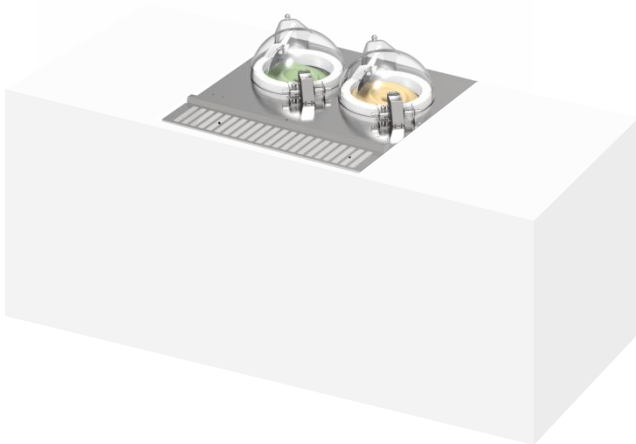

If the machine is embedded in the bar counter, the front glass must be replaced with dedicated ventilation panel.

The manufacturer installs the ventilation panel by default before the product leaves the factory.

1.8 How to replace the glass

Instructions for Replacing Ventilation Panel with Glass (Illustration using V4 as an example).

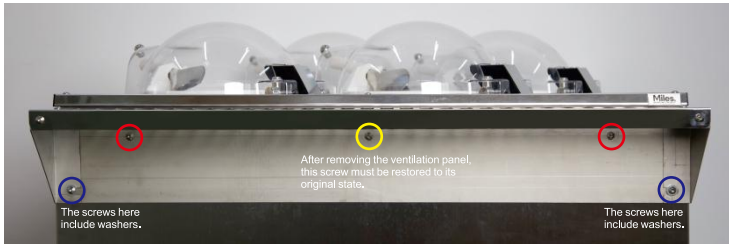

- 1 Remove the screws within the circle.



- 2 After unscrewing and removing the ventilation panel, install the glass mounting base screws (included in the accessory pack).

! The glass base screws and the ventilation panel screws are not the same type.









- 3 After completing the second step, align the glass holes with the corresponding base and tighten the nuts to complete the glass installation.

1.9

Warnings and residual risks



<p> Ambient temperature should not exceed 45°C.</p>	
<p> The power supply for the gelato (ice cream) machine must be consistent with the power supply specified on the nameplate, the standard three-hole socket (above 16A) must be used independently, and the socket must be grounded.</p>	<p> Plug and socket must contact firmly, otherwise may cause fire. Do not squeeze or pull the power plug. Do not damage the power cord.</p>
<p> Do not use if the power cord is damaged. Please contact the manufacturer as soon as possible, and go to the designated service point to replace. Do not dismantle, repair or modify without authorization.</p>	<p> In case of any abnormal phenomenon such as abnormal sound, smell, smoke and so on, please cut off the power supply and stop using immediately, and contact the service department of the manufacturer in time.</p>
<p> Do not place the machine near flammable or explosive materials. It is forbidden for surrounding devices to dissipate heat toward this machine.</p>	

1.10 Waste electrical and electronic equipment (WEEE)



In accordance with the European Directives 2006/66/EC (on batteries and accumulators and waste batteries and accumulators) and 2002/96/EC (also known as the WEEE Directive), the symbol attached to the product or its packaging indicates that this product should not be disposed of as ordinary municipal solid waste. Instead, it is the user's responsibility to deliver the product to a designated collection point for the proper disposal of waste electrical and electronic equipment. The separate collection of such waste facilitates the optimal recovery and recycling of reusable materials, while also minimizing the risks to human health and the environmental impact.

For more information on the correct disposal of this product, please contact your local authority or the retailer from whom the product was purchased.

2.1

Understanding the control interface



Click to start the command, double-click to stop the command.

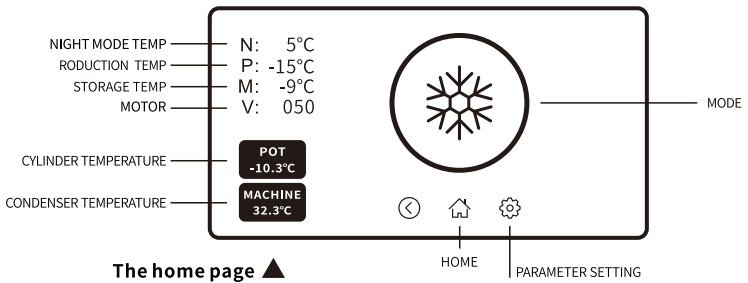

The home page ▲

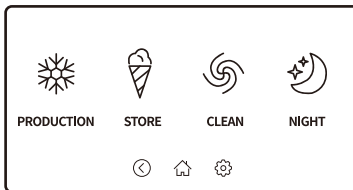

Mode selection

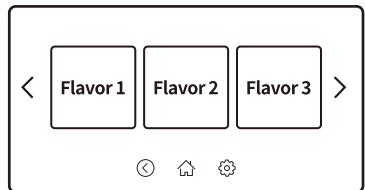

Flavor selection

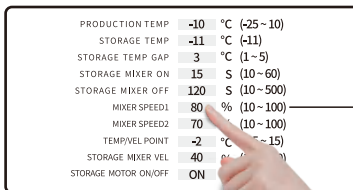

Parameter setting page

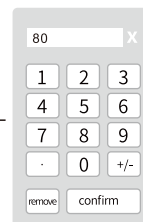

2.2

Cylinder cleaning (without ice cream)



- 1 Pour water into the cylinder. 2 Select the cleaning mode.

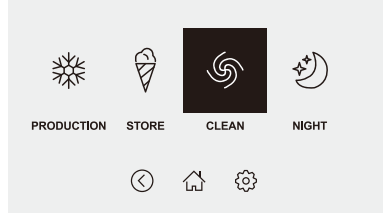

- 3 After 1-2 minutes, pull out the drainage block.



- 4 Collect the drain with a bucket.



- 5 After the water in the tank has been drained, use a kitchen paper towel or cloth to dry the inside of the tank.

2.3

LED spot light

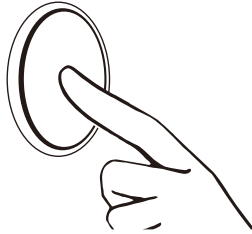
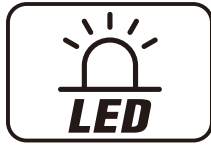

LED spot light



When removing the blade, be careful to avoid the LED light to prevent any damage.

2.4

Anti-fog & condensation system

**Anti-
fog &
condensation**

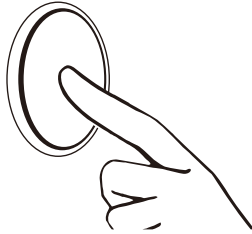

ON

OFF



Do not operate continuously for extended periods.
Turn it on only when the lid fogs up or condensation forms on the countertop.

2.5

Production capacity guidelines

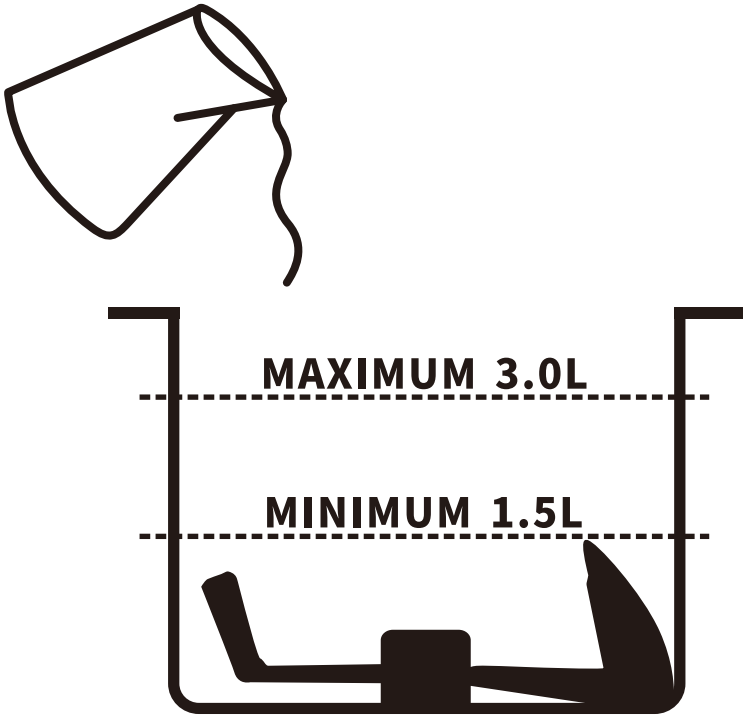

Less than the specified minimum starting amount will result in the ice cream not being fully stirred and formed..

2.6

Production modes and parameter adjustments



Pour the gelato mixture into the cylinder.

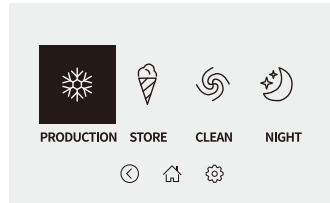

Select the “production” icon to start the batch.



Auto batching & churning.
--1.5-2L ready in 12 minutes
--2.0-3L ready in 20 minutes



When batching is finished, the gelato is ready to be served at storage mode.

PRODUCTION TEMP	-9	°C (-25 ~ 10)
STORAGE TEMP	-11	°C (-11)
STORAGE TEMP GAP	3	°C (1 ~ 5)
STORAGE MIXER ON	15	S (10 ~ 60)
STORAGE MIXER OFF	120	S (10 ~ 500)
MIXER SPEED1	80	% (10 ~ 100)
MIXER SPEED2	70	% (10 ~ 100)
TEMP/VEL POINT	-2	°C (-25 ~ 15)
STORAGE MIXER VEL	40	% (10 ~ 100)
STORAGE MOTOR ON/OFF	ON	

gelato & ice-cream suggested setting: -14°C to -16°C
sorbet suggested setting: -9°C to -11°C



If a temperature lower than -16°C is needed, please consult the manufacturer, as excessively low temperatures can cause the tank over freeze, which may damage the scraper.

This machine allows users to set two different speeds during the gelato freezing process. The higher the speed, the greater the overrun.

TEMP/VEL POINT

This setting is the temperature point at which the speed changes from Speed 1 to Speed 2.

2.7 Continuous production



1

Double-click to stop the storage mode.



2

Pour the mix directly on top of the remaining gelato.

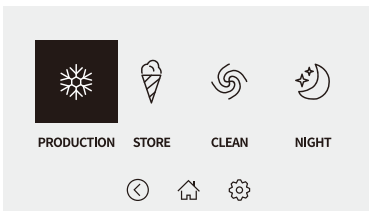

3

Click the “snow” icon to re-start production.



4

After the production is completed, the machine will automatically enter the storage mode again.

2.8

Storage mode and parameter adjustments

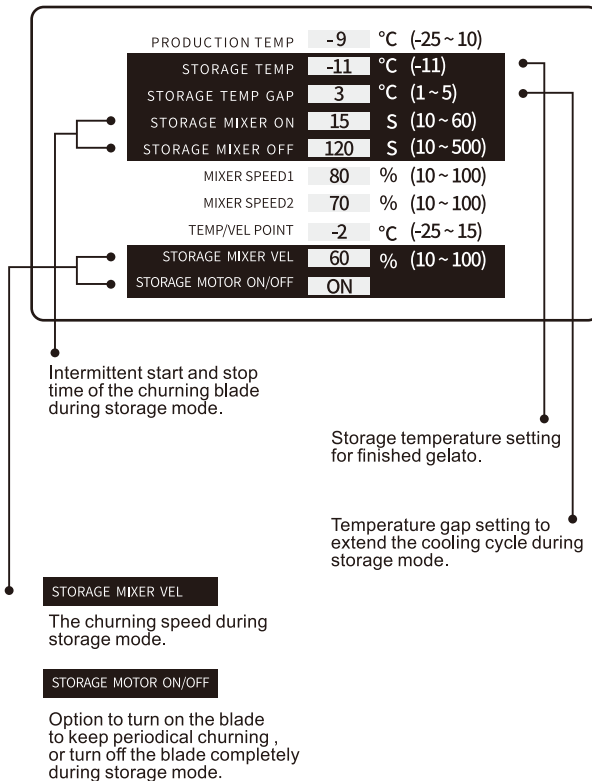
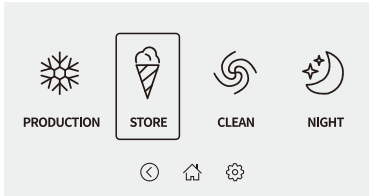

2.9

Night storage mode and parameter adjustments

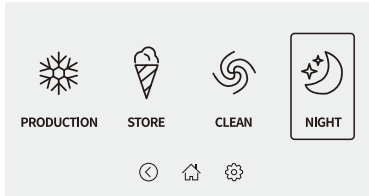

OPTION 1

NIGHT KEEP TEMP	0	°C (-10~5)
NIGHT KEEP TEMP GAP	1	°C (1~5)
NIGHT KEEP MIXER ON	10	S (10~60)
NIGHT KEEP MIXER OFF	150	S (10~500)
NIGHT MIXER VEL	20	% (10~100)
NIGHT MOTOR ON/OFF	OFF	

Age mode overnight storage



OPTION 2

NIGHT KEEP TEMP	-10	°C (-10~5)
NIGHT KEEP TEMP GAP	3	°C (1~5)
NIGHT KEEP MIXER ON	10	S (10~60)
NIGHT KEEP MIXER OFF	150	S (10~500)
NIGHT MIXER VEL	20	% (10~100)
NIGHT MOTOR ON/OFF	ON	

Freeze mode overnight storage

2.10

Standard cleaning procedures(with gelato in pot)



1 Double click to quit the storage mode.



2 Use both hands to hold both arms of the blade, and take it out from the cylinder.



3 Rinse the scraper and blade thoroughly.



4 Use both hands to hold both arms of the blade and slide it down steadily along the central shaft until it reaches the bottom of the cylinder



5 Pour water into the cylinder.



6 Select the cleaning mode.

2.10 Standard cleaning procedures



- 7 After 1-2 minutes, pull out the drainage block.



- 8 Collect the drain with a bucket.



- 9 After the water in the tank has been drained, use a kitchen paper towel or cloth to dry the inside of the tank.

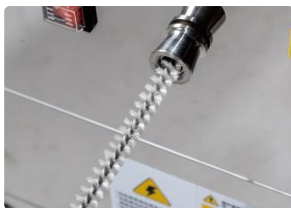

Clean the drain pipe with a brush.



Do not turn on the cleaning mode while using a brush to clean the drain pipe.

3.1 Daily maintenance (lid & counter top cleaning)



Use a soft cloth or kitchen paper to clean.
Do not use hard cleaning tools, as they may leave scratches on the transparent cover.



Use a food-grade stainless steel cleaner to wipe the countertop.

3.1

Daily maintenance (silicone ring cleaning)



Unlock the silicone ring.



Clean thoroughly with water and detergent.

3.2

Periodic maintenance (Scraper/O-rings/Dustproof net)



Scraper

 If it is damaged or severely worn, please replace it immediately.



O-rings

 If it is damaged or severely worn, please replace it immediately.



Dustproof net

Factory recommendation:
Clean with a brush once a month.

 Long-term lack of cleaning will lead to dust accumulation, causing malfunction of the refrigeration system.

3.2

Periodic maintenance (Seal kit replacement)



Seal kit replacement

 If the "Replace Seal" icon appears on the control screen, replace it immediately.



1

Use the dedicated tool provided in the spare parts kit to unscrew the seal kit (rotate clockwise).



2

Remove the old seal kit and install the new seal kit.



3

Use the dedicated tool to tighten (rotate counterclockwise).

 It is recommended to contact the manufacturer after replacement to confirm if it has been properly installed.

3.3

Emergency and malfunctions

EMERGENCY

ISSUE	TROUBLESHOOTING PLAN
<p>When the machine is severely overheating:</p> <p>When the condenser temperature displayed on the screen exceeds 55°C.</p> 	<p>Immediately stop using it and check if the machine is ventilating properly.</p>
<p>Potential short circuit issue:</p> <p>If the device frequently trips the circuit, this indicates a leakage protection activation.</p>	<p>Immediately stop using it, turn off the power, and check if the ground wire is correctly connected.</p>
<p>When the ice cream lid is opened but the stirring paddle does not stop operating:</p>	<p>Immediately stop using it, turn off the power, and contact the manufacturer to report a failure in the safety activation sensor, which needs to be replaced promptly.</p>

MALFUNCTION

ISSUE	TROUBLESHOOTING PLAN
<p>When the machine fails to start:</p>	<p>Please check if the circuit is connected correctly.</p>
<p>When the machine is completely unable to cool:</p>	<p>Check if the fuse has blown, and if so, replace the fuse.</p>
<p>When there is abnormal noise inside the tank during machine operation:</p>	<p>Check if the stirring scraper is severely worn and needs replacement.</p>
<p>When the machine's control screen suddenly goes black:</p>	<p>The machine may have entered protection mode; try unplugging it, plugging it back in, and turning it on.</p>
<p>When the stirring paddle cannot start:</p>	<p>Check if the tank is in a frozen state.</p>
<p>When the production speed slows down:</p>	<p>Check if the machine's air intake is blocked by dust and if the heat dissipation area is obstructed.</p>

If the malfunction cannot be resolved on-site following the above recommendations, please contact the manufacturer for technical support.

3.4

Warranty information

WARRANTY CARD

**MODEL
& SERIAL NUMBER :** /

DATE OF PURCHASE:

CUSTOMER:

HANGZHOU GELATO TECH CO.,LTD.

No.585 Shushangwang, Jinhua Town, Xiaoshan District,
Hangzhou, China

✉ Service@milestac.com

-
1. The manufacturer provides a 24-month warranty service for the equipment purchased by the Buyer (time calculated from the date of shipment). Free repairs are provided during the warranty period, labor and parts.
 2. The manufacturer provides remote technical guidance to ensure correct repair by the Buyer for consumption components.
 3. During on-site repairs, the manufacturer bears the costs of lodging, travel expense, and spare parts; domestic logistics cost for sending repairs are borne by the manufacturer.
 4. During the use of the equipment, if there are adjustability faults due to improper use by the Buyer, the manufacturer will provide remote guidance to assist in the proper operation of the equipment. If component damage is caused by improper use by the Buyer, the warranty policy does not apply. In this situation, the replacement costs are borne by the Buyer.

Miles.[®]
REDEFINE THE BEST



EC DECLARATION OF CONFORMITY (Original EC Declaration of Conformity)

We,

Hangzhou Gelato Tech Co., Ltd.

NO. 585 SHUSHANGWANG, JINHUA TOWN, XIAOSHAN DISTRICT, HANGZHOU CHINA 311253

hereby declare that the product:

- **Product:** Smart Gelato Ice-cream Machine

satisfies all the essential requirements of the following Directives:

- Directive 2006/42/EC (Machinery Directive)
- Directive 2014/35/EU (Low Voltage Directive)
- Regulation (EC) No 1935/2004 (Materials and articles intended to come into contact with food)
- Directive 2014/30/EU (Electromagnetic Compatibility Directive)
- Directive 2011/65/UE (RoHS)

Authorized Representative:

Europe Gateway International B.V
Bezoekadres Kraijenhoffstraat 137 A, 1018RG Amsterdam, The Netherlands
Tel:+31202444325, E-Mail: info@euegi.nl

Person authorized to compile the technical file in accordance with Annex VII of Directive 2006/42/EC:

Tomas Pen, Europe Gateway International B.V
Bezoekadres Kraijenhoffstraat 137 A, 1018RG Amsterdam the Netherlands

Standards applied:

EN ISO12100:2010, EN 60335-1:2012/A15:2021, EN IEC 60335-1:2023/All:2023, EN IEC
60335-2-75:2023/All:2023, EN IEC 55014-1:2021, EN IEC 55014-2:2021, EN IEC 61000-3-
2:2019/Al:2021/A2:2024, EN 61000-3-3:2013/Al:2019/A2:2021

Hangzhou, 02/01/2025

The Hangzhou Gelato Tech
General Manager

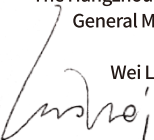
Wei Luo

Europe Gateway International B.V.
Bezoekadres Krajenhoffstraat 137 A, 1018RG
Amsterdam, the Netherlands
Telefon: +31202444325
E-Mail: info@euegi.nl



To whom it may concern

Amsterdam, 02.25.2025

Confirmation of EU Representative

This is to confirm that in accordance with Contract No.: EGI20250225101, Europe Gateway International B.V. agrees to perform all duties and responsibilities as the Authorized Representative for the manufacturer

Hangzhou Gelato Tech Co., Ltd.

NO. 585 SHUSHANGWANG, JINHUA TOWN, XIAOSHAN DISTRICT, HANGZHOU
CHINA 311253

as stipulated and demanded by the requirements established in EU representative contract.

Product: Smart Gelato Ice-Cream Machine

The manufacturer has provided Europe Gateway International B.V. with the appropriate Declaration(s) of Conformity claiming that the product(s) fulfills/fulfill the applicable requirements of the CE Regulation.

Safety Officer
Europe Gateway International B.V.



Cert No.: EGI20250225101
Issued date: Feb.25.2025
Valid until: Feb.24.2026

GALAXY PRO

V2/V2C/V4/V4C/V6/V8

OPERATION MANUAL

Miles.[®]

Hangzhou Gelato Tech Co., Ltd.

No. 585 Shushangwang, Jinhua Town, Xiaoshan District,
Hangzhou, China
Post code:311253