



6234-C / 6234A-C

SOFT SERVE FREEZER

Two Flavor, Countertop, Dual Controls
A: Pump Feed Model



Most **Compact & Versatile**
two-flavor countertop model with
independent intelligent controls
for ice cream and frozen yogurt

Fast Freeze Down

Patented high efficiency heat exchanger allows fast freeze down with low energy consumption

Digital Control and Display

Microprocessor control provides access to system settings and additional functions. Digital interface displays critical info as system status, temperatures, dispense count, errors, etc.

Operation Logging

Logs every operation and error to provide history and data for easy troubleshooting

Auto Programming

Allows automatic switching of operation modes based on preset schedules

Hopper Agitators

Maintain product consistency and prevent product separation

Ideal for any restaurants, convenience stores, dessert stands and delis to serve ice cream and gelato. Small foot print and low energy consumption help reduce operating cost.

Soft System Start

Slow motor start reduces equipment noise and stress on drive train

Direct Drive Transmission

Eliminates consumable moving parts and increases transmission efficiency

Defrost for Cleaning

Increases efficiency during cleaning by heating frozen product in cylinder

Quick Freeze

Turn on freeze immediately to freeze down to serving viscosity when quick service is required after long idle period

Self Closing Valve with Speed Control

Automatically prevents product overflow after dispense; Provides flexibility in dispense rate control

Safety Protections

- Low temperature and motor overload shutoffs to protect in the event of cylinder freeze up
- High pressure switch to prevent compressor overheating



6234-C / 6234A-C

SOFT SERVE FREEZER

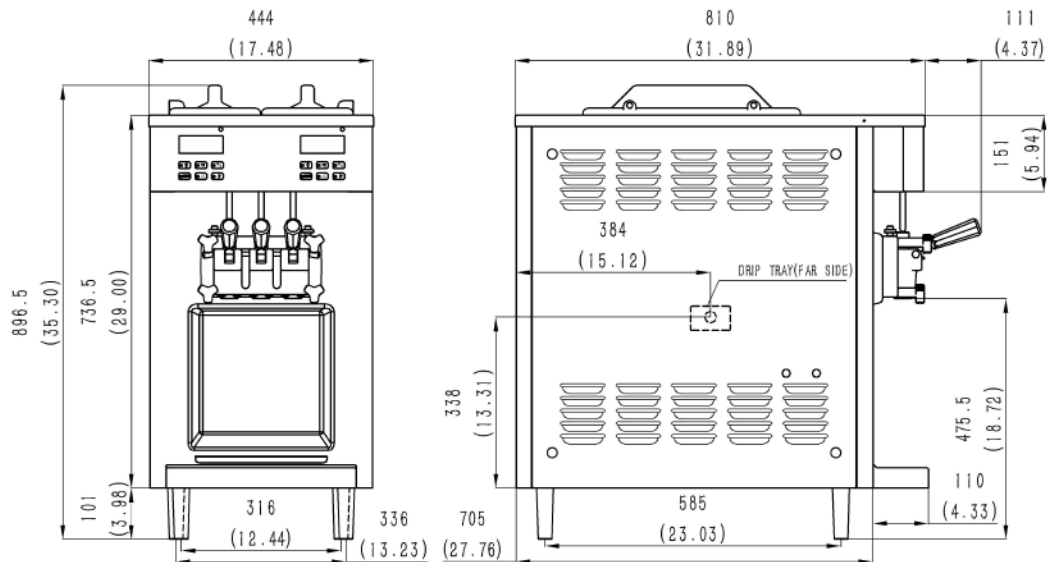

SPECIFICATIONS

Flavors	2 + Twist
Freezing Cylinders	2 x 1.2L / 1.3qt
Mix Hoppers	2 x 8.0L (5L for A)
Output Capacity (80 grams)	280 serves/hr
Clearance Requirements	None

Weight

	Kg/lb (Gravity)	Kg/lb (Pump)
Net	126 / 280	135 / 300
Shipping	141 / 313	150 / 330
Volume	0.48 CBM / 16.95 CBF	

Dimensions

	Net (mm/in)	Shipping (mm/in)
Width	444 / 17.5	530 / 20.9
Depth	705 / 27.8	830 / 32.7
Height	897 / 35.3	1080 / 42.5

Electrical

	MFS	MCA	Power(kW)
220-240/50/1	15	11	1.9
208-230/60/1	15	11	2.0

FEATURES

Control Systems	Double, Digital
Refrigerated Hoppers	✓
Hopper Agitators	✓
Temperature Display	✓
Standby Mode	✓
Auto Closing Dispensing Valves	✓
Dispensing Speed Control	✓
Low Mix Indicator Light & Alarm	✓
Low Temperature Protection	✓
Motor Overload Protection	✓
High Pressure Protection	✓
Defrost & Quick Freeze	✓
Soft Start	✓
Direct Drive Pump (A only)	✓

AVAILABLE OPTIONS

Water Cooled	✓
Cart (Trolley)	✓

• Above specifications are subject to change without notice